

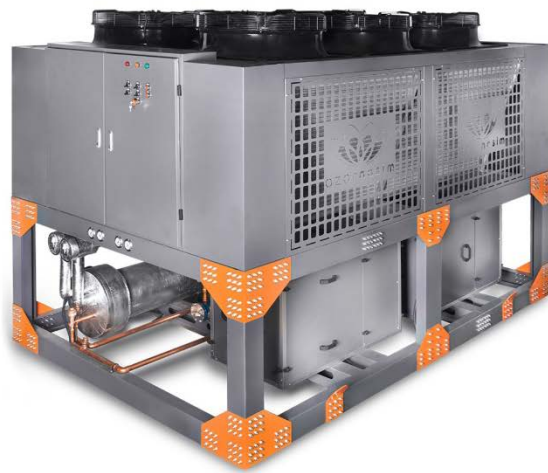

azarnasim
AIR CONDITIONING COMPANY

CHILLER



Introduction

Azar Nasim liquid chillers are designed for applications which require high performance, cost reduction and capability to operate in all conditions. These chillers are manufactured up to 320 RT in the integrated type and in higher capacities in the separate type. Although both air cooled and water cooled water chiller are available. Azar Nasim systems have proven their value in many different situations, from industrial applications to commercial spaces and from hotels to department stores. The attention paid at the design stage to the combination of compressor and electronics management, have enabled us to achieve extraordinary results in terms of both efficiency and durability. This combination enables Azar Nasim to produce various water-cooling solutions, designed specifically to use R-134a, 407C and R-22 refrigerants.

Nomenclature

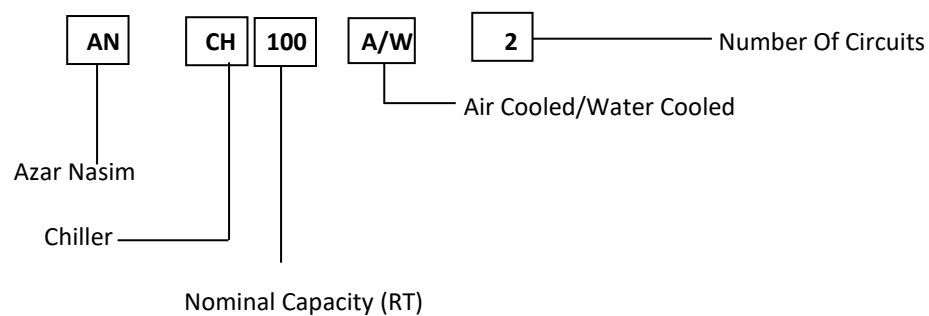

Main Component Features

1. Structure

Structure specifically is designed for outdoor installation. Basement and frame in galvanized shaped sheet steel with a suitable thickness. All parts have electro-static paint coating to assure all weather resistance. The evaporator and the suction piping are appropriately insulated to prevent condensation. Unit is provided with lifting holes.

2. Compressor

There are several widely used compressors from great and reputable vendors for AN CH series. All compressors are provided with motor winding temperature protection, discharge temperature protection, phase reversal protection, phase failure protection and oil level protection.

Hermetic scroll compressor (10 to 120 USTR) complete with motor over-temperature and over-current devices and protection against excessive gas discharge temperature. Fitted on rubber antivibration mounts and complete with oil charge. In scroll compressors, the refrigerant gas is compressed between the faces of two interlocking scrolls, one of which orbits while the other remains stationary.



Screw Compressors (°0 to 420 USRT) are directly flanged on a three stage oil separator with low oil carry over and pressure drop eliminator to ensure minimal refrigerant dilution in the oil and maintain high oil viscosity. Oil sight glass, oil drain valve, oil heater, discharge check valve, discharge stop valve are available as standard.

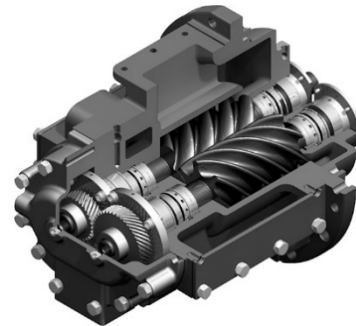
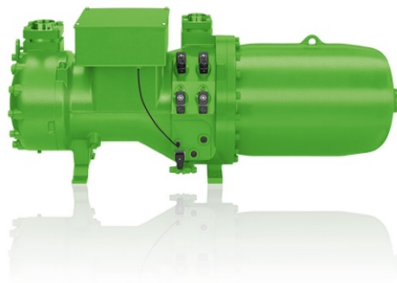

Reciprocating Compressors (10 to 280 USTR) are positive displacement type compressors as are scrolls and screws. In a reciprocating compressor, the refrigerant vapor is compressed by movement of the piston in a cylinder. With multiple cylinders, cylinders are selectively loaded or unloaded, based on set pressures (reflecting the temperatures);. Unloading implies that the suction valve is kept open so that the vapor, taken in during the suction stroke, returns back through the suction valves itself during the discharge stroke. Reciprocating compressors cannot tolerate liquid slugging, which can happen when the evaporator load is less and the superheat controlled expansion valve is unable to regulate the flow of refrigerant correctly, resulting in excess liquid refrigerant entering the evaporator and getting sucked into the compressor. Liquid slugging can cause serious damage to the compressor.

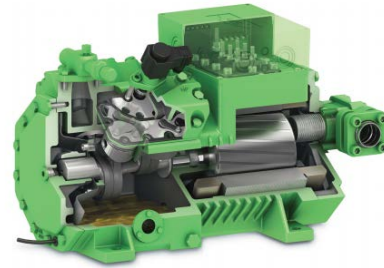
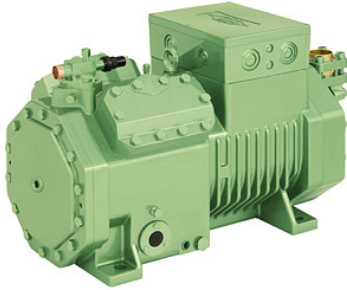

3. Fan

Low speed, axial-flow fans installed with accident-prevention protective grille; directly coupled motor with built-in thermal cut-out and IP 54/55 protection degree; aerodynamic housing and wing profile blades increase efficiency and decrease noise level.

4. Condensers

Air Cooled Condenser coils are manufactured from copper tubes mechanically bonded to aluminum fins to ensure optimum heat transfer. All coils are pressure tested at factory at 420 psig.

Condenser fin materials should be matched with site conditions to inhibit coil corrosion and ensure extended equipment life.

Water Cooled condensers are shell and cleanable , through-tube type. The unit has independent condensers, one per circuit. Each condenser has a carbon steel and seamless, integrally finned high efficiency copper tubes, roll expanded into heavy carbon steel tube sheets. Water sides are removable and include vent and drain plugs. Condensers become complete with liquid shut-off valve, spring loaded relief valve.

5. Evaporator

All extremely efficient with low refrigerant charge and very stable operating performance due to excellent refrigerant distribution, thermally insulated by vapor-proof closed cell.

Evaporator shell is made of carbon steel, Tubes are made of copper based on TEMA standard.

The refrigerants passed through the expansion device that passed into tubes and evaporates to generate a cooling effect.

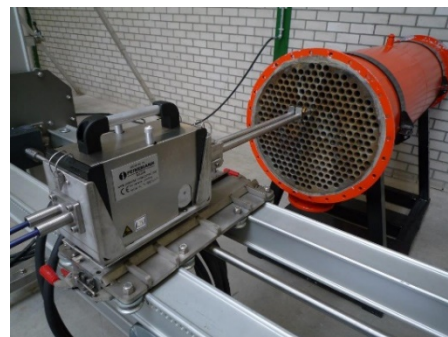

6. Refrigerant circuit

Each refrigerant circuit is completely independent and complete with all control and regulation devices such as: stop valves, gauges, solenoid stop valves, filter driers, liquid sight glass and expansion valves. Refrigerant circuits perform a pump down when the compressor stops.

7. Power And Control Panel

PLC Controller is an advanced numeric control system; programmable for weekly, daily and hourly schedules in which enhances the air-cooled and water-cooled chillers by providing the very latest chiller control technology that combines intelligence with great operating simplicity. The control constantly monitors all machine parameters and precisely manages the operation of compressors and adjusting chiller parameter. Leaving or entering cooler water temperature controls chiller on/off and continuously control compressor capacity to match required load and It is possible to controls condenser fan speed using inverter.

Chiller PLC system can be integrated with building management system (BMS).

8. Permanent Working Chillers

Permanent working chillers are designed and manufactured for industrial four-season applications.

• Air Cooled – Scroll-R134a- One Circuit

Table1-Technical Data Scroll Compressor-R134a								
Models		AN CH 12-A-1	AN CH 13-A-1	AN CH 15-A-1	AN CH 20-A-1	AN CH 25-A-1	AN CH 30-A-1	
Nominal Cooling Capacity	RT	12	13	15	20	25	30	
Compressor	Type	Scroll						
	Quantity	1	1	1	1	1	1	
Refrigerant	Type	R134a						
Oil Charge	Lit	3.4	3.4	3.9	4.7	6.8	6.8	
Condenser	Type	Air Cooled - Copper Tubes, Aluminum Fins						
	Total Coil Face Area	Ft^2	28.4	28.4	28.4	28.4	49.7	49.7
	Row/FPI		2/12	2/10	2/10	2/10	2/10	2/10
	Maximum Heat Rejection	MBH	79.8	92.4	123.2	155	178.1	242.3
Condenser Fan	Type & Speed	Axial, low-noise / 900 RPM						
	Quantity	1	1	1	1	2	2	
Refrigerant Charge	R134a	13.2	14.3	16.5	22	27.5	33	
Evaporator	Type	Shell & Tube						
Electrical Data	Current(A)	17.97	20.9	25.64	29.4	38.78	46.51	
	Locked Rotor Current (A)	118	140	174	225	272	310	
	Power Input(kW)	10.2	11.5	13.8	15.5	21.6	25.3	
Weight	kg	800	800	950	1200	1250	1600	

Table2-Performance Data Scroll Compressor-R134a Water Leaving Temperature 45°F (7.2°C) COP Range: 2.2 - 4																
Model	Condensing Temperature															
	113°F (45°C)				122°F(50°C)				131°F(55°C)				140°F(60°C)			
	Actual Cooling Capacity	Evaporator		Power Input (kW)	Actual Cooling Capacity	Evaporator		Power Input (kW)	Actual Cooling Capacity	Evaporator		Power Input (kW)	Actual Cooling Capacity	Evaporator		Power Input (kW)
	RT	Water Flow Rate (GPM)	Pressure Drop (Ft.W.g)	kW	RT	Water Flow (GPM)	Pressure Drop (Ft.W.g)	kW	RT	Water Flow (GPM)	Pressure Drop (Ft.W.g)	kW	RT	Water Flow (GPM)	Pressure Drop (Ft.W.g)	kW
AN CH 12-A-1	6.06	14.54	2	5.62	5.66	13.58	2.1	6.31	5.13	12.31	2.2	7.05	4.78	11.46	2.3	7.8
AN CH 13-A-1	6.51	15.63	2.2	6.2	5.97	14.33	2.3	6.85	5.64	13.55	2.4	7.63	5.1	12.25	2.5	8.57
AN CH 15-A-1	7.76	18.63	3	7.51	7.28	17.47	3.1	8.33	6.74	16.17	3.2	9.26	6.11	14.67	3.3	10.3
AN CH 20-A-1	9.98	23.95	1.7	9.98	9.38	22.52	1.8	11.1	8.81	21.16	1.9	12.3	8.22	19.72	2	13.6
AN CH 25-A-1	12.34	29.62	2.3	14.45	11.63	27.91	2.4	13.8	10.92	26.21	2.5	15.35	10.21	24.5	2.6	17.1
AN CH 30-A-1	15.61	37.47	3.2	15.3	14.76	35.42	3.3	16.9	13.85	33.23	3.4	18.7	12.97	31.12	3.5	20.7

• Air Cooled – Scroll-R134a- Two Circuit

Table 3-Technical Data Scroll Compressor-R134												
Models		AN CH 20-A-2	AN CH 24-A-2	AN CH 26-A-2	AN CH 30-A-2	AN CH 40-A-2	AN CH 50-A-2	AN CH 60-A-2	AN CH 80-A-2	AN CH 100-A-2	AN CH 120-A-2	
Nominal Cooling Capacity	RT	20	24	26	30	40	50	60	80	100	120	
Compressor	Type	Scroll										
	Quantity	2	2	2	2	2	2	2	4	4	4	
Refrigerant	Type	R134a										
Oil Charge	Lit	6.8	6.8	6.8	7.8	9.4	13.6	12.6	18.8	25.2	27.2	
Condenser	Type	Air Cooled - Copper Tubes, Aluminum Fins										
	Total Coil Face Area	Ft^2	56.81	56.81	56.81	56.81	56.81	99.42	99.42	99.42	149.13	149.13
	Row / FPI		2/10	2/10	2/10	3/10	4/10	2/10	3/10	4/12	3/10	4/12
	Maximum Heat Rejection	MBH	160	185	200.6	246.4	309.8	356.3	484.6	619.7	712.6	846.4
Condenser Fan	Type & Speed	Axial, low-noise / 900 RPM										
	Quantity	2	2	2	2	2	4	4	4	6	6	
Refrigerant Charge	R134a	20.2	26.4	28.6	33	44	55	66	88	110	132	
Evaporator	Type	Shell & Tube										
Electrical Data	Current(A)	35.04	35.94	41.8	51.28	58.8	77.56	93.02	117.6	147.72	178.64	
	Locked Rotor Current (A)	236	236	280	348	450	544	620	900	1088	1240	
	Power Input(kW)	19.9	20.3	23.1	27.5	31.1	43.3	50.6	62.1	79.7	94.3	
Weight	kg	1200	1200	1600	2000	2050	2500	1350	3100	3400	3650	

Table 4-Performance Data Scroll Compressor-R134a Water Leaving Temperature 45°F (7.2°C) COP Range: 2.2 - 4																
Model	Condensing Temperature															
	113°F (45°C)				122°F(50°C)				131°F(55°C)				140°F(60°C)			
	Actual Cooling Capacity	Evaporator		Power Input (kW)	Actual Cooling Capacity	Evaporator		Power Input (kW)	Actual Cooling Capacity	Evaporator		Power Input (kW)	Actual Cooling Capacity	Evaporator		Power Input (kW)
RT	Water Flow Rate (GPM)	Pressure Drop (Ft.W.g)	kW	RT	Water Flow (GPM)	Pressure Drop (Ft.W.g)	kW	RT	Water Flow (GPM)	Pressure Drop (Ft.W.g)	kW	RT	Water Flow (GPM)	Pressure Drop (Ft.W.g)	kW	
AN CH 20-A-2	10.35	24.84	3.6	10.12	9.67	23.2	3.8	11.2	8.96	21.5	4	12.36	8.25	19.79	4.2	13.64
AN CH 24-A-2	12.11	29.07	4	11.24	11.32	27.16	4.2	12.62	10.26	24.62	4.4	14.1	9.5	22.93	4.6	15.6
AN CH 26-A-2	13.02	31.26	4.4	12.4	11.94	28.66	4.6	13.7	11.29	27.09	4.8	15.26	10.21	24.5	5	17.14
AN CH 30-A-2	15.53	37.26	6	15.02	14.56	34.94	6.2	16.66	13.48	32.35	6.4	18.52	12.23	29.34	6.6	20.6
AN CH 40-A-2	19.96	47.91	3.4	19.96	18.77	45.04	3.6	22.2	17.63	42.31	3.8	24.6	16.44	39.44	4	27.3
AN CH 50-A-2	24.68	59.23	4.6	28.9	23.26	55.82	4.8	27.6	21.84	52.41	5	30.7	20.42	49	5.2	34.2
AN CH 60-A-2	31.22	74.93	6.4	30.6	29.52	70.84	6.6	33.8	27.7	66.47	6.8	37.4	25.93	62.24	7	41.4
AN CH 80-A-2	39.92	95.81	12	39.92	37.53	90.08	12.4	44.4	35.26	86.42	12.8	49.2	32.87	78.89	13.2	54.6
AN CH 100-A-2	49.36	118.47	6.8	57.8	46.52	111.65	7.2	55.2	43.68	104.82	7.6	61.4	40.83	98	8	68.4
AN CH 120-A-2	62.44	149.86	9.2	61.2	59.03	141.67	9.6	67.6	55.39	132.94	10	74.8	51.86	124.47	10.4	82.8

• Air Cooled-Scroll-R22- One Circuit

Table 5-Technical Data Scroll Compressor-R22								
Models		AN CH 12-A-1	AN CH 13-A-1	AN CH 15-A-1	AN CH 20-A-1	AN CH 25-A-1	AN CH 30-A-1	
Nominal Cooling Capacity	RT	12	13	15	20	25	30	
Compressor	Type	Scroll						
	Quantity	1	1	1	1	1	1	
Refrigerant	Type	R22						
Oil Charge	Lit	3.4	3.4	3.9	4.7	6.8	6.8	
Condenser	Type	Air Cooled - Copper Tubes, Aluminum Fins						
	Total Coil Face Area	Ft^2	28.4	28.4	49.7	49.7	49.7	49.7
	Row / FPI		3/12	3/12	2/10	3/10	3/12	2/10
	Maximum Heat Rejection	MBH	138.4	150.8	189.4	234.1	290.6	359.7
Condenser Fan	Type & Speed	Axial, low-noise / 900 RPM						
	Quantity	1	1	2	2	2	4	
Refrigerant Charge	R22	13.2	14.3	16.5	22	17.5	33	
Evaporator	Type	Shell & Tube						
Electrical Data	Current(A)	21.41	24.03	33.12	37.14	45.56	45.46	
	Locke Rotor Current(A)	118	140	174	225	272	310	
	Power Input(kW)	10	11.3	17.2	19.1	23.1	26.5	
Weight	kg	800	800	950	1200	1250	1600	

Table 6-Performance Data Scroll Compressor-R22 Water Leaving Temperature 45°F (7.2°C) COP Range: 2.2 - 4												
Model	Condensing Temperature											
	113°F (45°C)				122°F(50°C)				131°F(55°C)			
	Actual Cooling Capacity	Evaporator		Power Input	Actual Cooling Capacity	Evaporator		Power Input	Actual Cooling Capacity	Evaporator		Power Input
	RT	Water Flow Rate (GPM)	Pressure Drop (Ft.W.g)	kW	RT	Water Flow Rate (GPM)	Pressure Drop (Ft.W.g)	kW	RT	Water Flow Rate (GPM)	Pressure Drop (Ft.W.g)	kW
AN CH 12-A-1	9.16	21.97	2.3	8.16	8.62	20.68	2.5	9.1	8.05	19.31	2.6	10.15
AN CH 13-A-1	9.9	23.57	2.5	9.2	9.27	22.25	2.7	10.15	8.59	20.61	2.8	11.3
AN CH 15-A-1	11.72	28.12	3.3	11.1	11	26.41	3.5	12.35	10.18	24.43	3.6	13.7
AN CH 20-A-1	15.27	36.65	2	14.5	14.5	34.8	2.2	16.05	13.65	32.76	2.3	17.85
AN CH 25-A-1	18.97	45.52	2.8	17.9	17.9	42.99	3	19.95	16.78	40.26	3.1	22.2
AN CH 30-A-1	23.57	56.57	3.7	21.9	22.41	53.78	3.9	24.2	21.13	50.7	4	26.8

• Air Cooled-Scroll-R22 - Two Circuits

Table 7-Technical Data Scroll Compressor-R22														
Models		AN CH 16-A-2	AN CH 18-A-2	AN CH 20-A-2	AN CH 24-A-2	AN CH 26-A-2	AN CH 30-A-2	AN CH 40-A-2	AN CH 50-A-2	AN CH 60-A-2	AN CH 80-A-2	AN CH 100-A-2	AN CH 120-A-2	
Nominal Cooling Capacity	RT	16	18	20	24	26	30	40	50	60	80	100	120	
	Type	Scroll												
Compressor	Quantity	2	2	2	2	2	2	2	2	2	4	4	4	
	Type	R22												
Refrigerant	Lit	5.4	6.8	6.8	6.8	6.8	7.8	9.4	13.6	12.6	18.8	27.2	27.2	
Oil Charge	Type	Air Cooled - Copper Tubes, Aluminum Fins												
	Total Coil face Area	Ft^2	56.81	56.81	56.81	56.81	56.81	99.42	99.42	99.42	149.13	149.13	198.84	248.56
	Row/FPI		2/10	2/10	3/10	3/12	3/12	2/10	3/10	3/12	3/10	4/12	3/12	3/12
Condenser	Maximum Heat Rejection	MBH	182.2	206.2	242.5	276.8	301.7	378.8	468.2	581.2	719.45	936.5	1162.4	1438.9
	Type & Speed	Axial, low-noise / 900 RPM												
Condenser Fan	Quantity	2	2	2	2	2	4	4	4	6	6	8	10	
	Refrigerant Charge	R22	17.6	19.8	20.2	26.4	28.6	33	44	55	66	88	110	132
Evaporator	Type	Shell & Tube												
	Current(A)	32.66	35.06	39.12	42.82	48.06	66.24	74.28	91.12	113.5	117.6	147.72	178.64	
Electrical Data	Locked Rotor Current(A)	190	222	236	236	280	348	450	544	620	900	1088	1240	
	Power Input(kW)	17	18.2	20.1	21.8	24.3	36.2	40	47.9	61.9	62.1	79.7	94.3	
Weight	kg	1150	1150	1200	1200	1600	2000	2050	2500	2850	3200	3500	3850	

Table 8-Performance Data Scroll Compressor-R22 Water Leaving Temperature 45°F (7.2°C) COP Range: 2.2 - 4												
Model	Condensing Temperature											
	113°F (45°C)				122°F (50°C)				131°F (55°C)			
	Actual Cooling Capacity	Evaporator		Power Input	Actual Cooling Capacity	Evaporator		Power Input	Actual Cooling Capacity	Evaporator		Power Input
	RT	Water Flow Rate (GPM)	Pressure Drop (Ft.W.g)	kW	RT	Water Flow Rate (GPM)	Pressure Drop (Ft.W.g)	kW	RT	Water Flow Rate (GPM)	Pressure Drop (Ft.W.g)	kW
AN CH 16-A-2	12	28.8	3.8	10.96	11.29	27.09	4.2	12.22	10.52	25.25	4.4	13.66
AN CH 18-A-2	13.59	32.62	4	12.2	12.85	30.85	4.4	13.58	12.11	29.07	4.6	15.18
AN CH 20-A-2	15.98	38.35	4.2	14.46	15.13	36.31	4.6	16.18	14.27	34.26	4.8	18.14
AN CH 24-A-2	18.31	43.95	4.6	16.32	17.23	41.36	5	18.2	16.09	38.63	5.2	20.3
AN CH 26-A-2	19.79	47.5	5	18.4	18.54	44.49	5.4	20.3	17.17	41.22	5.6	22.6
AN CH 30-A-2	23.43	56.23	6.6	22.2	22.01	52.82	7	24.7	20.36	48.86	7.2	27.4
AN CH 40-A-2	30.54	73.29	4	29	29	69.61	4.4	32.1	27.3	65.51	4.6	35.7
AN CH 50-A-2	37.93	91.04	5.6	35.8	35.83	85.99	6	39.9	33.55	80.53	6.2	44.4
AN CH 60-A-2	47.14	113.15	7.4	43.8	44.81	107.55	7.8	48.4	42.25	101.41	8	53.6
AN CH 80-A-2	61.08	146.59	8	58	58.01	139.22	8.8	64.2	54.59	131.03	9.2	71.4
AN CH 100-A-2	75.86	182.07	11.2	71.6	71.65	171.97	12	79.8	67.11	161.05	12.4	88.8
AN CH 120-A-2	94.29	226.29	14.8	87.6	89.63	215.1	15.6	96.8	84.51	202.82	16	107.2

• Air Cooled-Reciprocating-R134a - One Circuit

Table 9-Technical Data Reciprocating Compressor - R134a									
Models		AN CH 15-A-1	AN CH 20-A-1	AN CH 25-A-1	AN CH 30-A-1	AN CH 35-A-1	AN CH 40-A-1	AN CH 50-A-1	
Nominal Cooling Capacity	RT	15	20	25	30	35	40	50	
Compressor	Type	Reciprocating							
	Quantity	1	1	1	1	1	1	1	1
Refrigerant	Type	R134a							
Oil Charge	Lit	2.6	2.6	4.5	4.5	4.75	4.75	4.75	
Condenser	Type	Air Cooled - Copper Tubes, Aluminum Fins							
	Total Coil Face Area	Ft^2	28.41	28.41	28.41	49.71	49.71	49.71	49.71
	ROW/FPI		2/12	3/10	4/12	2/12	3/12	4/10	2/10
	Maximum Heat Rejection	MBH	110.6	132	176.3	205.4	259.6	302.9	360
Condenser	Type & Speed	Axial, low-noise / 900 RPM							
	Fan		1	1	1	2	2	2	2
Refrigerant Charge	R134a	16.5	22	27.5	33	38.5	44	55	
Evaporator	Type	Shell & Tube							
Electrical Data	Current(A)	47	47	47	56.4	56.4	66.4	88	
	Locked Rotor Current(A)	81	97	125	141	165	219	226	
	Power Input(kW)	24	24	24	32	32	38	50	
Weight	kg	560	600	620	730	840	1000	1100	

Table 10-Performance Data Reciprocating Compressor-R134a Water Leaving Temperature 45°F (7.2°C) COP Range: 2.1 - 3.6																
Model	Condensing Temperature															
	113°F (45°C)				122°F (50°C)				131°F (55°C)				140°F (60°C)			
	Actual Cooling Capacity	Evaporator		Power Input	Actual Cooling Capacity	Evaporator		Power Input	Actual Cooling Capacity	Evaporator		Power Input	Actual Cooling Capacity	Evaporator		Power Input
RT	Water Flow Rate (GPM)	Pressure Drop (Ft.W.g)	kW	RT	Water Flow (GPM)	Pressure Drop (Ft.W.g)	kW	RT	Water Flow (GPM)	Pressure Drop (Ft.W.g)	kW	RT	Water Flow (GPM)	Pressure Drop (Ft.W.g)	kW	
AN CH 15-A-1	7.06	16.93	2.7	7	6.47	15.52	2.8	7.37	5.91	14.18	2.9	7.67	5.33	12.8	2.3	7.92
AN CH 20-A-1	8.43	20.23	3.5	8.36	7.76	18.61	3.7	8.83	7.11	17.07	3.9	9.24	6.47	15.52	3.2	9.58
AN CH 25-A-1	11.28	27.08	4.3	10.94	10.44	25.07	4.5	11.59	9.6	23.05	4.6	12.19	8.76	21.03	3.7	12.72
AN CH 30-A-1	13.16	31.58	14.3	12.77	12.18	29.23	12	13.49	11.23	26.95	9.5	14.14	10.25	24.6	8.3	14.74
AN CH 35-A-1	16.58	39.78	14.3	16.34	15.34	36.83	16.8	17.31	14.08	33.8	22	18.15	12.82	30.78	25.5	18.88
AN CH 40-A-1	19.21	46.1	14.3	19.49	17.86	42.87	21.7	20.7	16.52	39.65	34.5	21.7	15.12	36.29	42.4	22.7
AN CH 50-A-1	22.76	54.63	10.3	23.3	21.06	50.53	9.2	24.5	19.32	46.37	9	25.6	17.58	42.2	9.4	26.5

• Air Cooled-Reciprocating-R134a - Two Circuit

Table 11-Technical Data Reciprocating Compressor - R134a										
Models		AN CH 20-A-2	AN CH 30-A-2	AN CH 40-A-2	AN CH 50-A-2	AN CH 60-A-2	AN CH 70-A-2	AN CH 80-A-2	AN CH 100-A-2	
Nominal Cooling Capacity	RT	20	30	40	50	60	70	80	100	
Compressor	Type	Reciprocating								
	Quantity	2	2	2	2	2	2	2	2	
Refrigerant	Type	R134a								
Oil Charge	Lit	5.2	5.2	5.2	9	9	9.5	9.5	9.5	
Condenser	Type	Air Cooled - Copper Tubes, Aluminum Fins								
	Total Coil Face Area	Ft^2	56.81	56.81	56.81	56.81	99.42	99.42	99.42	149.3
	Row/FPI		2/10	2/12	3/10	4/12	2/12	3/12	4/10	3/10
	Maximum Heat Rejection	MBH	160.2	221.2	264	352.6	410.9	519.3	605.8	720.1
Condenser Fan	Type	Axial, low-noise / 900 Rpm								
	Quantity	2	2	2	2	4	4	4	6	
Refrigerant Charge	R134a	22	33	44	55	66	77	88	110	
Evaporator	Type	Shell & Tube								
Electrical Data	Current(A)	47	56.4	66.4	88	102.4	128	147.8	192.4	
	Locked Rotor Current(A)	148	162	194	250	282	330	438	452	
	Power Input(kW)	24	32	38	50	56	72	84	102	
Weight	kg	700	780	1050	1090	1150	1634	1775	1850	

Table 12-Performance Data Reciprocating Compressor-R134a Water Leaving Temperature 45°F (7.2°C) COP Range: 2.1 - 3.6																
Model	Condensing Temperature															
	113°F (45°C)				122°F(50°C)				131°F(55°C)				140°F(60°C)			
	Actual Cooling Capacity	Evaporator		Power Input (kW)	Actual Cooling Capacity	Evaporator		Power Input (kW)	Actual Cooling Capacity	Evaporator		Power Input (kW)	Actual Cooling Capacity	Evaporator		Power Input (kW)
RT	Water Flow Rate (GPM)	Pressure Drop (Ft.W.g)	kW	RT	Water Flow (GPM)	Pressure Drop (Ft.W.g)	kW	RT	Water Flow (GPM)	Pressure Drop (Ft.W.g)	kW	RT	Water Flow (GPM)	Pressure Drop (Ft.W.g)	kW	
AN CH 20-A-2	10.2	24.51	3.5	10.12	9.39	22.54	3.7	10.64	8.57	18.64	32	11.08	7.77	18.64	32	11.46
AN CH 30-A-2	14.11	33.87	14.3	14			14.74	11.82	28.36	9.5	15.34	10.67	25.6	8.3	15.84	
AN CH 40-A-2	16.86	40.45	14.3	55.4	15.51	37.23	21.7	17.66	14.22	34.14	46.2	18.48	12.94	31.05	42.4	19.6
AN CH 50-A-2	22.57	54.16	10.3	21.88	20.89	50.13	9.2	23.18	19.21	46.1	9	24.38	17.53	42.07	9.4	25.44
AN CH 60-A-2	26.32	63.17	31.8	25.54	24.36	58.46	27.2	26.98	22.46	53.89	22.9	28.28	20.5	49.19	21	29.48
AN CH 70-A-2	33.15	79.56	11.4	32.68	30.69	73.65	9.6	34.62	28.17	67.6	7.7	36.3	25.37	60.88	6.9	37.76
AN CH 80-A-2	38.42	92.2	20.6	38.98	35.73	85.75	17.7	41.4	33.04	79.3	14.9	43.4	30.24	72.58	13.7	45.4
AN CH 100-A-2	45.53	109.27	32.4	46.6	42.03	100.87	27.7	49	38.64	92.74	23.3	51.2	35.17	84.4	21.4	53

• Air Cooled -Reciprocating– R22 - One Circuit

Table 13-Technical Data Reciprocating Compressor - R22									
Models		AN CH 15-A-1	AN CH 20-A-1	AN CH 25-A-1	AN CH 30-A-1	AN CH 35-A-1	AN CH 40-A-1	AN CH 50-A-1	
Nominal Cooling Capacity	RT	15	20	25	30	35	40	50	
Compressor	Type	Reciprocating							
	Quantity	1	1	1	1	1	1	1	1
Refrigerant	Type	R22							
Oil Charge	Lit	2.6	2.6	4.5	4.5	4.75	4.75	4.75	4.75
Condenser	Type	Air Cooled - Copper Tubes, Aluminum Fins							
	Total Coil Face Area	Ft^2	28.42	49.73	49.73	49.73	99.46	99.46	99.46
	Row/FPI		4/12	2/12	3/12	4/12	2/12	3/10	3/12
	Maximum Heat Rejection	MBH	176.6	207.2	275.9	319.1	414.6	475.4	572.69
Condenser Fan	Type	Air Cooled - Copper Tubes, Aluminum Fins							
	Quantity	1	2	2	2	4	4	4	4
Refrigerant Charge	R22	16.5	22	27.5	33	38.5	44	55	
Evaporator	Type	Shell & Tube							
Electrical Data	Current(A)	28.2	33.2	44	51.2	64.4	73.9	96.2	
	Locked Rotor Current(A)	81	97	125	141	165	219	226	
	Power Input(kW)	16	19	25	28	36	42	51	
Weight	kg	560	600	620	730	840	1000	1100	

Table 14-Performance Data Reciprocating Compressor-R22a Water Leaving Temperature 45°F (7.2°C) Cop Range: 2.8 - 3.6												
Model	Condensing Temperature											
	113°F (45°C)				122°F(50°C)				131°F(55°C)			
	Actual Cooling Capacity	Evaporator		Power Input	Actual Cooling Capacity	Evaporator		Power Input	Actual Cooling Capacity	Evaporator		Power Input
RT	Water Flow Rate (GPM)	Pressure Drop (Ft.W.g)	kW	RT	Water Flow (GPM)	Pressure Drop (Ft.W.g)	kW	RT	Water Flow (GPM)	Pressure Drop (Ft.W.g)	kW	
AN CH 15-A-1	11.28	27.08	2.7	11.03	10.56	25.33	2.8	11.75	9.86	23.65	2.9	12.41
AN CH 20-A-1	13.27	31.85	3.5	12.9	12.46	29.9	3.7	13.77	11.62	27.89	3.9	14.59
AN CH 25-A-1	17.64	42.34	4.3	17.28	16.58	39.78	4.5	18.49	15.51	37.23	4.6	19.65
AN CH 30-A-1	20.44	49.06	14.3	19.87	19.24	46.17	12	21.3	18	43.21	9.5	22.7
AN CH 35-A-1	26.49	63.57	14.3	26.1	24.86	59.67	16.8	28	23.27	55.84	22	29.8
AN CH 40-A-1	30.41	72.98	14.3	29.8	28.56	68.54	21.7	31.9	26.71	64.11	34.5	33.9
AN CH 50-A-1	36.57	87.76	10.3	36.2	34.38	82.52	9.2	38.7	32.2	77.28	9	41.2

• Air Cooled -Reciprocating– R22 - Two Circuits

Table15-Technical Data Reciprocating Compressor - R22										
Models		AN CH 20-A-2	AN CH 30-A-2	AN CH 40-A-2	AN CH 50-A-2	AN CH 60-A-2	AN CH 70-A-2	AN CH 80-A-2	AN CH 100-A-2	
Nominal Cooling Capacity	RT	20	30	40	50	60	70	80	100	
Compressor	Type	Reciprocating								
	Quantity	2	2	2	2	2	2	2	2	
Refrigerant	Type	R22								
Oil Charge	Lit	5.2	5.2	5.2	9	9	9.5	9.5	9.5	
Condenser	Type	Air Cooled - Copper Tubes, Aluminum Fins								
	Total Coil Face Area	Ft^2	56.81	56.81	99.42	99.42	99.42	149.13	149.13	198.84
	Row/FPI		2	2	4	4	4	6	6	8
	Maximum Heat Rejection	MBH	254.6	253.2	414.5	551.8	638.2	829.3	950.8	1145.3
Condenser Fan	Type	Axial, low-noise / 900 RPM								
	Quantity	2	2	4	4	4	6	6	8	
Refrigerant Charge	R22	22	33	44	55	66	77	88	110	
Evaporator	Type	Shell & Tube								
Electrical Data	Current(A)	39.8	56.4	66.4	88	102.4	128	147.8	192.4	
	Locked Rotor Current(A)	118	162	194	250	282	330	438	452	
	Power Input(kW)	24	32	38	50	56	72	84	102	
Weight	kg	700	780	1050	1090	1150	1634	1775	1850	

Table 16-Performance Data Reciprocating Compressor-R22 Water Leaving Temperature 45°F (7.2°C) COP: 2.8 - 3.6												
Model	Condensing Temperature											
	113°F (45°C)				122°F(50°C)				131°F(55°C)			
	Actual Cooling Capacity	Evaporator		Power Input	Actual Cooling Capacity	Evaporator		Power Input	Actual Cooling Capacity	Evaporator		Power Input
	RT	Water Flow Rate (GPM)	Pressure Drop (Ft.W.g)	kW	RT	Water Flow (GPM)	Pressure Drop (Ft.W.g)	kW	RT	Water Flow (GPM)	Pressure Drop (Ft.W.g)	kW
AN CH 20-A-2	16.3	39.11	3.5	15.78	15.29	36.69	3.7	16.8	14.22	34.14	3.9	17.78
AN CH 30-A-2	22.57	54.16	14.3	22.06	21.11	50.67	12	23.5	19.71	47.31	9.5	24.82
AN CH 40-A-2	26.54	63.71	14.3	25.8	24.92	59.81	21.7	27.54	23.24	55.78	34.5	29.18
AN CH 50-A-2	35.28	84.67	10.3	34.56	33.15	79.56	9.2	36.98	31.02	74.46	9	39.3
AN CH 60-A-2	40.88	98.11	31.8	39.74	38.47	92.33	27.2	42.6	36.01	86.42	22.9	45.4
AN CH 70-A-2	52.98	127.14	11.4	52.2	49.73	119.35	9.6	56	46.54	111.69	7.7	59.6
AN CH 80-A-2	60.82	145.96	20.6	59.6	57.12	137.09	17.7	63.8	53.42	128.22	14.9	67.8
AN CH 100-A-2	73.14	175.53	32.4	72.4	68.77	165.04	27.7	77.4	64.4	154.56	23.3	82.4

• Air Cooled-Screw - R22

Table 17-Technical Data Screw Compressor-R22																	
Models		AN CH 50-A-1	AN CH 60-A-1	AN CH 70-A-1	AN CH 80-A-1	AN CH 90-A-1	AN CH 100-A-2	AN CH 120-A-2	AN CH 140-A-2	AN CH 160-A-2	AN CH 180-A-2	AN CH 200-A-2	AN CH 220-A-2	AN CH 250-A-2	AN CH 280-A-2	AN CH 320-A-2	
Nominal Cooling Capacity	RT	50	60	70	80	90	100	120	140	160	180	200	220	250	280	320	
Compressor	Type	Screw															
	Quantity	1	1	1	1	1	2	2	2	2	2	2	2	2	2	2	
Refrigerant	Type	R22															
Oil Charge	Lit	9.5	9.5	15	15	15	30	30	30	30	30	30	44	44	44	38	
Condenser	Type	Air Cooled - Copper Tubes, Aluminum Fins															
	Total Coil Face Area	Ft^2	99.42	99.42	149.13	149.13	149.13	149.13	198.84	248.56	248.56	298.27	347.6	397.69	397.69	497.11	546.82
	Row/FPI		3/10	4/10	3/10	3/12	4/12	4/12	4/10	3/12	4/12	4/12	4/12	4/12	4/12	4/12	4/12
Condenser Fan	Type & Speed	Axial, low-noise / 900 Rpm															
	Quantity	4	4	6	6	6	6	8	10	10	12	14	16	16	20	22	
Refrigerant Charge	R22	kg	55	66	77	88	99	110	132	154	176	198	220	242	275	308	352
Electrical Data	Type	Shell & Tube															
	Current(A)	82.4	97.6	120.2	132.1	146.6	157.4	195.2	233	256.8	293.2	337.4	385.8	414	490	529.4	
	Locked Rotor Current(A)	218	269	290	350	423	438	538	580	700	846	958	1040	1224	1330	1458	
Weight	Power Input(kW)	58.8	71.8	88.2	98.2	106.2	114.2	143.6	173	193	212.4	227.8	251.2	291.2	334	357.4	
	kg	2000	2150	3000	3150	3350	3650	4200	5500	5800	6400	6700	7850	8450	9800	10350	

Table 18-Performance Data Screw Compressor-R22 Water Leaving Temperature 45°F (7.2°C) COP Range: 2.4 - 3.8												
Model	Condensing Temperature											
	113°F (45°C)				122°F (50°C)				131°F (55°C)			
	Actual Cooling Capacity	Evaporator		Power Input	Actual Cooling Capacity	Evaporator		Power Input	Actual Cooling Capacity	Evaporator		Power Input
	RT	Water Flow Rate (GPM)	Pressure Drop (Ft.W.g)	kW	RT	Water Flow Rate (GPM)	Pressure Drop (Ft.W.g)	kW	RT	Water Flow Rate (GPM)	Pressure Drop (Ft.W.g)	kW
AN CH 50-A-1	31.62	75.89	9.1	33	29.69	71.25	8.9	36.3	28.52	68.45	8.7	38.5
AN CH 60-A-1	39.67	95.2	12.4	40.9	37.28	89.47	12.2	45	35.8	85.92	12	47.8
AN CH 70-A-1	46.21	110.89	17.5	49.3	42.79	102.71	17.3	54.2	40.6	97.45	17.1	57.4
AN CH 80-A-1	53.51	128.43	7.3	55.6	49.39	118.54	7.1	60.8	46.75	112.19	6.9	64.2
AN CH 90-A-1	64.55	154.91	9.3	64	60.28	144.67	9.1	70.2	57.15	137.17	8.9	74.3
AN CH 100-A-2	63.24	151.77	10.5	66	59.37	142.49	10.2	72.6	57.04	136.9	10	77
AN CH 120-A-2	79.33	190.4	12.6	81.8	74.56	178.93	12.3	90	71.6	171.84	12.1	95.6
AN CH 140-A-2	92.41	221.79	15.8	98.6	85.59	205.41	15.4	108.4	81.21	194.9	15.2	114.8
AN CH 160-A-2	107.03	256.87	18.4	111.2	98.78	237.08	18	121.6	93.49	224.38	17.8	128.4
AN CH 180-A-2	129.09	309.82	6.6	128	120.56	289.35	6.2	140.4	114.31	274.34	6	148.6
AN CH 200-A-2	142.17	341.21	8.1	146.4	133.07	319.38	7.7	160.8	126.82	304.36	7.5	170.6
AN CH 220-A-2	162.08	388.98	11.7	167	151.27	363.05	11.2	183.2	144.45	346.67	11	194.6
AN CH 250-A-2	175.16	420.38	10	174.6	162.08	388.98	9.5	193	154.11	369.88	9.3	205.6
AN CH 280-A-2	208.14	499.54	13.8	213.8	193.92	465.42	13.4	232.6	208.14	499.54	13	213.8
AN CH 320-A-2	232.59	558.23	16.4	227.8	217.24	521.37	15.9	249	207	499.54	15.5	263

• Air Cooled-Screw-R134a

Table 19-Technical Data
Screw Compressor - R134a

Models		AN CH 50-A-1	AN CH 60-A-1	AN CH 70-A-1	AN CH 80-A-1	AN CH 90-A-1	AN CH 100-A-2	AN CH 120-A-2	AN CH 140-A-2	AN CH 160-A-2	AN CH 180-A-2	AN CH 200-A-2	AN CH 220-A-2	AN CH 250-A-2	AN CH 280-A-2	AN CH 320-A-2	AN CH 420-A-2	
Nominal Cooling Capacity	RT	50	60	70	80	90	100	120	140	160	180	200	220	250	280	320	420	
Compressor	Type	Screw																
	Quantity	1	1	1	1	1	2	2	2	2	2	2	2	2	2	2	2	
Refrigerant	Type	Screw																
Oil Charge	Lit	15	15	15	30	22	30	30	30	44	44	44	44	44	60	60	60	
Condenser	Type	Air Cooled - Copper Tubes, Aluminum Fins																
	Total Coil Face Area	Ft^2	99.42	99.42	99.42	149.13	149.13	150.52	200.69	198.84	248.56	298.27	248.56	347.98	347.98	397.69	497.11	497.11
	Row/FPI		3/10	3/12	4/12	3/12	4/10	4/12	3/12	4/12	4/12	4/10	4/10	4/10	4/12	4/12	4/12	4/12
Maximum Heat Rejection	MBH	4720	553.58	634.8	774.74	887.37	949.4	1107.16	1116	1549.48	1774.7	1474.4	2081.9	2293.5	3078.49	3092	3078	
	Quantity	4	4	4	6	6	6	8	8	10	12	10	14	14	16	20	22	
Refrigerant Charge	R134a	kg	55	66	77	88	99	110	132	154	176	198	220	242	275	308	352	
Electrical Data	Type	Shell & Tube																
	Current(A)	86	96.5	107	129.3	148.2	164.6	193	214	251	296.4	277.6	346	384.6	435.8	500	562	
	Locked Rotor Current(A)	206	267	290	394	439	412	534	580	788	878	1032	1040	1224	1330	872	881	
Weight	Power Input(kW)	58.8	71.8	84.4	98.2	106.2	114.2	143.6	169.6	193	212.2	241	243	263.8	289.2	344	431	
	kg	2000	2100	2550	3200	3300	3600	3950	4550	6000	6350	5400	7100	7300	7800	10000	10000	

Table 20-Performance Data
Screw Compressor-R134
Water Leaving Temperature 45°F (7.2°C)
COP Range: 2 - 3.7

Model	Condensing Temperature															
	113°F (45°C)				122°F (50°C)				131°F (55°C)				140°F (60°C)			
	Actual Cooling Capacity		Evaporator		Power Input	Actual Cooling Capacity		Evaporator		Power Input	Actual Cooling Capacity		Evaporator		Power Input	
	RT	Water Flow Rate (GPM)	Pressure Drop (Ft.W.g)	kW	RT	Water Flow Rate (GPM)	Pressure Drop (Ft.W.g)	kW	RT	Water Flow Rate (GPM)	Pressure Drop (Ft.W.g)	kW	RT	Water Flow Rate (GPM)	Pressure Drop (Ft.W.g)	kW
AN CH 50-A-1	30.51	73.22	8.2	30.1	28.15	67.56	7.9	33.2	25.7	61.69	7.7	36.8	23.2	55.69	7.5	40.8
AN CH 60-A-1	35.94	86.26	8.6	34.7	33.18	79.64	8.3	38.3	30.34	72.82	8.1	42.4	27.41	65.79	7.9	47
AN CH 70-A-1	41.32	99.16	12.5	39.4	38.16	91.58	12.2	43.5	34.89	83.73	12	42.7	31.56	75.75	11.8	53.4
AN CH 80-A-1	50.36	120.86	8.7	48	47	112.81	8.4	53	43.53	104.48	8.2	58.9	39.95	95.88	8	65.8
AN CH 90-A-1	58.01	139.22	12.2	54.7	54.17	130	11.9	60.4	50.19	120.45	11.7	67.2	46.06	110.55	11.5	75
AN CH 100-A-2	48.11	115.47	10.6	60.2	56.3	135.12	15.8	66.4	51.41	123.38	15.4	73.6	46.41	111.37	15	81.6
AN CH 120-A-2	71.88	172.52	17.2	69.4	66.37	159.28	16.6	76.6	60.68	145.63	16.2	84.4	54.82	131.57	15.8	94
AN CH 140-A-2	82.63	198.31	25	78.8	76.32	183.16	24.4	87	69.78	167.47	24	85.4	63.12	151.5	23.6	106.8
AN CH 160-A-2	100.71	241.72	17.4	96	94	225.61	16.8	106	87.07	208.96	16.4	117.8	79.9	191.76	16	131.6
AN CH 180-A-2	116.01	278.43	24.4	109.4	108.34	260.01	23.8	120.8	100.37	240.9	23.4	134.4	92.13	221.11	23	150
AN CH 200-A-2	96.22	230.93	21.2	91.2	89.8	215.51	20.6	100.6	83.03	199.27	20.2	111.2	76.03	182.48	19.8	122.8
AN CH 220-A-2	136.49	327.57	26.6	124.2	126.82	304.36	26	137.4	116.58	279.8	25.6	152.6	106.74	256.18	25	170.4
AN CH 250-A-2	150.7	361.69	19.8	139.6	140.47	337.12	19.2	154.4	129.66	311.19	18.8	171.6	118.86	285.25	18.2	191.4
AN CH 280-A-2	171.74	412.19	22.6	159	159.8	383.52	22	175.8	147.86	354.86	21.6	195.4	135.35	324.84	21	218
AN CH 320-A-2	203.59	488.62	27.8	186.6	189.37	454.5	27.2	206.2	174.02	417.65	26.6	228	158.66	380.79	26	252
AN CH 420-A-2	201.88	484.52	22.4	185.6	188.24	451.77	21.8	204.8	173.45	416.28	21.2	226.4	158.66	380.79	20.6	250.2

• **Air Cooled Chillers Dimensions** (Based on The Quantity of Fans)

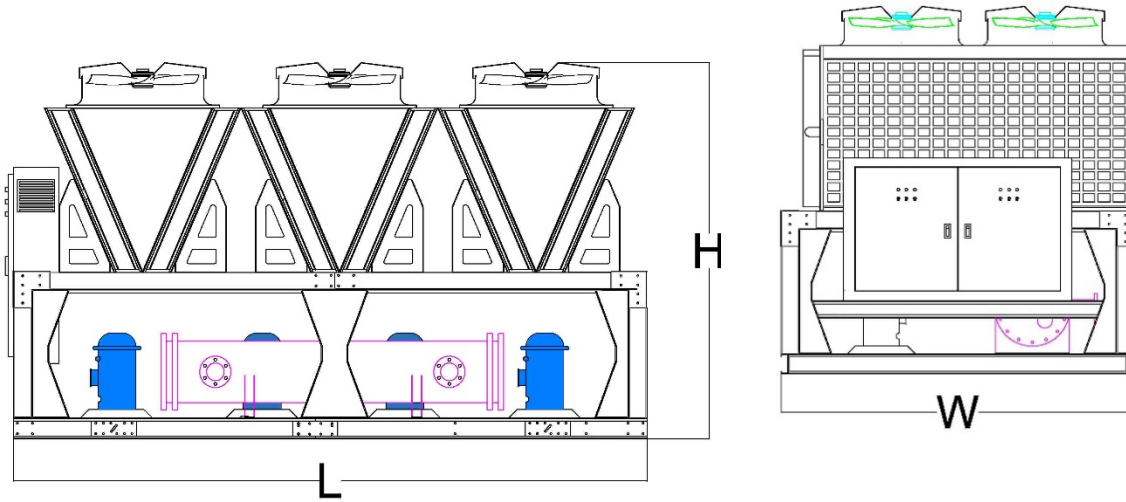

Table 21

Quantity Of Fan	2	4	6	8	10	12	14	16	18	20	22	24	26
W	2400	2400	2400	2400	2400	2400	2400	2400	2400	2400	2400	2400	2400
L	1450	2630	3800	4960	6130	7300	8450	9620	10780	11950	13110	14280	15250
H	2500	2500	2500	2500	2500	2500	2500	2500	2500	2500	2500	2500	2500

Note:

Fan Size (Diameter): 800 mm

Dimensions are in mm

- Water Cooled – Scroll Compress

Table 22

Technical Data
Scroll Compressor

Model	Nominal Cooling Capacity RT	Compressor		Number Of Circuits	Oil Charge Lit	Refrigerant	Refrigerant Charge kg	Condenser		Evaporator Type	Weight kg
		Type	Quantity					Type	Quantity		
AN CH 12-W-1	12	Scroll	1	1	3.4	R134a , R407C , R22	12	Shell & Tube	1	Shell & Tube	450
AN CH 13-W-1	13		1	1	3.4		13		1		450
AN CH 15-W-1	15		1	1	3.9		15		1		500
AN CH 20-W-1	20		1	1	4.7		20		1		750
AN CH 25-W-1	25		1	1	6.8		25		1		750
AN CH 30-W-1	30		1	1	6.3		30		1		800
AN CH 10-W-2	10		2	2	3.4		10		2		600
AN CH 12-W-2	12		2	2	3.6		12		2		600
AN CH 14-W-2	14		2	2	3.6		14		2		600
AN CH 16-W-2	16		2	2	5.4		16		2		650
AN CH 18-W-2	18		2	2	6.8		18		2		650
AN CH 20-W-2	20		2	2	6.8		20		2		650
AN CH 24-W-2	24		2	2	6.8		24		2		650
AN CH 26-W-2	26		2	2	6.8		26		2		700
AN CH 30-W-2	30		2	2	7.8		30		2		800
AN CH 40-W-2	40		2	2	9.4		40		2		950
AN CH 50-W-2	50		2	2	13.6		50		2		950
AN CH 60-W-2	60		2	2	12.6		60		2		1100
AN CH 80-W-2	80		2	2	18.8		80		2		1400
AN CH 100-W-2	100		2	2	27.2		100		2		1650
AN CH 120-W-2	120	2	2	25.2	120	2	1700				

Table 23-Performance Data
Scroll Compressor-R22
Leaving Chilled Water Temperature: 45°F(7.2°C)
COP Range: 4.6 - 5.5

Model	Condenser Entering/Leaving Temperatures are 86/95°F(30/35°C)						Condenser Entering/Leaving Temperatures are 91.4/100.4°F(33/38°C)					
	Actual Capacity		Chilled Water		Condenser Water		Actual Capacity		Chilled Water		Condenser Water	
	RT	kW	GPM	P.D Ft of Water	GPM	P.D Ft of Water	RT	kW	GPM	P.D Ft of Water	GPM	P.D Ft of Water
AN CH 12-W-1	9.64	33.9	23.13	1.2	28.92	1.3	9.35	32.9	22.45	1.1	28.06	1.3
AN CH 13-W-1	10.44	36.7	25.05	1.3	31.31	1.4	10.12	35.6	24.29	1.2	30.37	1.4
AN CH 15-W-1	12.37	43.5	29.69	2	37.11	2.1	11.97	42.1	28.73	1.9	35.91	2.1
AN CH 20-W-1	16.01	56.3	38.42	2.7	48.03	2.8	15.24	53.6	36.58	2.6	45.72	2.8
AN CH 25-W-1	19.96	70.2	47.91	3.9	59.88	4.1	19.36	68.1	46.47	3.7	58.09	4.1
AN CH 30-W-1	24.65	86.7	59.17	6.4	73.96	6.6	24	84.4	57.6	6.2	72	6.6
AN CH 10-W-2	7.88	27.7	18.9	1	23.63	1.1	7.62	26.8	18.29	0.8	22.86	1.1
AN CH 12-W-2	9.58	33.7	23	1.1	28.75	1.2	9.3	32.7	22.32	0.9	27.89	1.2
AN CH 14-W-2	10.78	37.9	25.86	1.4	32.33	1.5	10.46	36.8	25.11	1.2	31.39	1.5
AN CH 16-W-2	12.62	44.4	30.3	1.9	37.87	2	12.23	43	29.34	1.7	36.68	2
AN CH 18-W-2	14.27	50.2	34.26	2.4	42.82	2.5	13.88	48.8	33.3	2.2	41.63	2.5
AN CH 20-W-2	16.78	59	40.26	2.9	50.33	3	16.32	57.4	39.17	2.7	48.96	3
AN CH 24-W-2	19.28	67.8	46.27	3.7	57.84	3.8	18.71	65.8	44.9	3.5	56.13	3.8
AN CH 26-W-2	20.87	73.4	50.09	4.1	62.61	4.1	20.25	71.2	48.59	3.9	60.74	4.1
AN CH 30-W-2	24.74	87	59.37	6.4	74.21	6.2	23.94	84.2	57.46	6.1	71.83	6.2
AN CH 40-W-2	32.02	112.6	76.84	10.6	96.05	10.4	30.48	107.2	73.16	10.3	91.45	10.4
AN CH 50-W-2	39.92	140.4	95.81	13.1	119.77	12.8	38.73	136.2	92.95	12.8	116.18	12.8
AN CH 60-W-2	49.31	173.4	118.33	18.6	147.92	18.5	48	168.8	115.19	18.3	143.99	18.5
AN CH 80-W-4	64.03	225.2	153.68	18.9	192.1	19	60.96	214.4	146.31	18.6	182.89	18.7
AN CH 100-W-4	79.84	280.8	191.63	19.1	239.53	19.2	77.46	272.4	185.89	18.8	232.37	18.9
AN CH 120-W-4	98.61	346.8	236.67	20.1	295.83	20.2	95.99	337.6	230.39	19.8	287.98	19.9

Table 24-Performance Data
Scroll Compressor-R134
Leaving Chilled Water Temperature: 45°F (7.2°C)
COP Range: 4.4 - 5.44

Model	Condenser Entering/Leaving Temperatures are 86/95°F(30/35°C)						Condenser Entering/Leaving Temperatures are 91.4/100.4°F(33/38°C)					
	Actual Capacity		Chilled Water		Condenser Water		Actual Capacity		Chilled Water		Condenser Water	
	RT	kW	GPM	P.D Ft of Water	GPM	P.D Ft of Water	RT	kW	GPM	P.D Ft of Water	GPM	P.D Ft of Water
AN CH 20-W-1	10.55	37.1	25.32	2.6	31.65	2.7	10.21	35.9	24.5	2.4	30.62	2.6
AN CH 25-W-1	13.02	45.8	31.26	3.9	39.07	4	12.62	44.4	30.3	3.7	37.87	3.9
AN CH 30-W-1	16.44	57.8	39.44	6.4	49.31	6.5	15.95	56.1	38.28	6.2	47.86	6.4
AN CH 10-W-2	5.27	18.52	12.64	1	15.8	1.1	5.1	17.92	12.23	0.8	15.29	1
AN CH 12-W-2	6.31	22.2	15.15	1	18.94	1.2	6.08	21.4	14.6	0.8	18.25	1.1
AN CH 14-W-2	7.02	24.7	16.86	1.3	21.07	1.5	6.8	23.9	16.31	1.1	20.39	1.4
AN CH 16-W-2	8.39	29.5	20.13	1.8	25.16	1.9	8.1	28.5	19.45	1.6	24.31	1.8
AN CH 18-W-2	9.41	33.1	22.59	2.1	28.24	2.3	9.1	32	21.84	1.9	27.3	2.2
AN CH 20-W-2	11.03	38.8	26.48	2.6	33.1	2.7	10.63	37.4	25.52	2.4	31.9	2.6
AN CH 24-W-2	12.8	45	30.71	3.4	38.39	3.5	12.4	43.6	29.75	3.2	37.19	3.4
AN CH 26-W-2	13.76	48.4	33.03	3.8	41.29	3.9	13.31	46.8	31.94	3.6	39.92	3.8
AN CH 30-W-2	16.38	57.6	39.31	6.1	49.13	6.2	15.87	55.8	38.08	5.9	47.6	6.1
AN CH 40-W-2	21.1	74.2	50.64	10.3	63.3	10.4	20.42	71.8	49	10.1	61.25	10.3
AN CH 50-W-2	26.05	91.6	62.51	12.8	78.14	12.9	25.25	88.8	60.6	12.6	75.75	12.8
AN CH 60-W-2	32.87	115.6	78.89	18.3	98.61	18.4	31.9	112.2	76.57	18.1	95.71	18.3
AN CH 80-W-4	42.2	148.4	101.27	19.3	126.59	20	40.83	143.6	98	19.1	122.5	19.8
AN CH 100-W-4	52.09	183.2	125.02	19.5	156.28	20.2	50.5	177.6	121.2	19.3	151.5	20
AN CH 120-W-4	65.74	231.2	157.78	20.5	197.22	21.2	63.81	224.4	153.14	20.3	191.42	21

• Water Cooled Screw Compressor – Two Circuits

Table 25 a-Technical Data Screw Compressor														
Models		AN CH 50-W-1	AN CH 60-W-1	AN CH 70-W-1	AN CH 80-W-1	AN CH 90-W-1	AN CH 100-W- 2	AN CH 120-W- 2	AN CH 140-W- 2	AN CH 160-W- 2	AN CH 180-W- 2	AN CH 200-W- 2	AN CH 220-W- 2	AN CH 250-W- 2
Nominal Cooling Capacity	RT	50	60	70	80	90	100	120	140	160	180	200	220	250
	Type	Screw												
Compressor	Quantity	1	1	1	1	1	2	2	2	2	2	2	2	2
	Refrigerant	R134a, R407C, R22												
Condenser	Type	Shell & Tube												
	Quantity	1	1	1	1	1	2	2	2	2	2	2	2	2
Evaporator	Type	Shell & Tube												
	Weight	kg	1150	1250	1950	2000	2100	2500	2650	3500	3600	3700	3850	5000

Table 25 b-Technical Data Screw Compressor						
Models		AN CH 280-W-2	AN CH 320-W-2	AN CH 360-W-2	AN CH 420-W-2	AN CH 480-W-2
Nominal Cooling Capacity	RT	280	320	360	420	480
	Type	Screw				
Compressor	Quantity	2	2	2	2	2
	Refrigerant	R134a, R407C, R22				
Condenser	Type	Shell & Tube				
	Quantity	2	2	2	2	2
Evaporator	Type	Shell & Tube				
	Weight	kg	5850	6100	6750	3950

Table 26-Performance Data Screw Compressor-R22 Leaving Chilled Water Temperature: 45°F (7.2°C) COP Range: 4 - 4.7												
Model	Condenser Entering/Leaving Temperatures are 86/95°F(30/35°C)						Condenser Entering/Leaving Temperatures are 91.4/100.4°F(33/38°C)					
	Actual Capacity		Chilled Water		Condenser Water		Actual Capacity		Chilled Water		Condenser Water	
	RT	kW	GPM	P.D Ft of Water	GPM	P.D Ft of Water	RT	kW	GPM	P.D Ft of Water	GPM	P.D Ft of Water
AN CH 50-W-1	33.55	118	80.53	8.7	100.66	10.2	32.39	113.9	77.73	8.5	97.16	9.9
AN CH 60-W-1	42.08	148	101	11.7	126.25	13.2	40.63	142.9	97.52	11.5	121.9	12.9
AN CH 70-W-1	49.33	173.5	118.4	16.2	148	17.7	47.49	167	113.97	16	142.46	17.4
AN CH 80-W-1	57.44	202	137.85	6.7	172.31	8.2	55.08	193.7	132.19	6.5	165.23	7.9
AN CH 90-W-1	68.81	242	165.15	8.7	206.43	10.2	66.25	233	159.01	8.5	198.76	9.9
AN CH 100-W-2	67.11	236	161.05	9.4	201.32	12	64.77	227.8	155.46	9.2	194.32	11.7
AN CH 120-W-2	84.17	296	202	11.6	252.5	14.1	81.27	285.8	195.04	11.5	243.8	13.8
AN CH 140-W-2	98.67	347	236.8	14.7	296	17.3	94.97	334	227.93	14.7	284.91	16.9
AN CH 160-W-2	114.88	404	275.7	17.4	344.63	19.9	110.16	387.4	264.37	17.3	330.47	19.5
AN CH 180-W-2	137.62	484	330.3	6.2	412.87	8.7	132.5	466	318.01	6.1	397.51	9.7
AN CH 200-W-2	151.27	532	363.05	7.4	453.81	10	146.15	514	350.77	7.2	438.46	11.8
AN CH 220-W-2	164.35	578	394.44	7.4	493.05	9.8	158.1	556	379.43	7.2	474.29	9.2
AN CH 250-W-2	187.1	658	449.04	9	561.3	11.7	179.71	632	431.29	8.8	539.12	11.2
AN CH 280-W-2	220.65	776	529.56	12.7	661.96	15.4	213.26	750	511.82	12.5	639.78	14.9
AN CH 320-W-2	246.81	868	592.35	15.7	740.43	18.4	238.28	838	571.87	15.5	714.84	17.9

Table 27-Performance Data

Screw Compressor-R134

Leaving Chilled Water Temperature: 40°F (7.2°C)

COP Range: 4.5 - 5

Model	Condenser Entering/Leaving Temperatures are 86/95°F(30/35°C)						Condenser Entering/Leaving Temperatures are 91.4/100.4°F(33/38°C)					
	Actual Capacity		Chilled Water		Condenser Water		Actual Capacity		Chilled Water		Condenser Water	
	RT	kW	GPM	P.D Ft Of Water	GPM	P.D Ft Of Water	RT	kW	GPM	P.D Ft Of Water	GPM	P.D Ft Of Water
AN CH 50-W-1	32.76	217	78.62	7.9	98.27	8.3	31.42	110.5	75.41	7.6	94.26	8.1
AN CH 60-W-1	38.59	135.7	92.61	8.3	115.76	8.7	37.02	130.2	88.85	8	111.07	8.5
AN CH 70-W-1	44.33	155.9	106.3 9	11.9	132.99	12.4	42.54	149.6	149.6	11.6	127.61	12.1
AN CH 80-W-1	53.57	188.4	128.5 7	8.5	160.71	9	51.64	181.6	123.93	8.2	154.91	8.7
AN CH 90-W-1	61.7	217	148.0 9	11.7	185.11	12.2	59.43	209	142.63	11.4	178.28	11.9
AN CH 100-W-2	65.51	230.4	157.2 3	15.8	196.54	16.1	62.84	221	150.82	15.4	188.52	15.8
AN CH 120-W-2	77.17	271.4	185.2 1	16.6	231.51	16.8	74.04	260.4	177.7	16.2	222.13	16.5
AN CH 140-W-2	88.66	311.8	212.7 8	23.8	265.98	24	85.08	299.2	204.18	23.4	255.23	23.7
AN CH 160-W-2	107.14	376.8	257.1 4	16.8	321.42	17.2	103.27	363.2	247.86	16.4	309.82	16.9
AN CH 180-W-2	123.41	434	296.1 7	23.2	370.22	23.6	118.86	418	285.25	22.8	356.57	23.3
AN CH 220-W-2	145.58	512	394.4 4	26.3	436.75	26.7	140.47	494	337.12	25.8	421.4	26.3
AN CH 250-W-2	160.94	566	386.2 5	19.1	482.82	19.5	154.68	544	371.24	18.6	464.05	19.1
AN CH 280-W-2	183.12	644	439.4 8	21.9	549.35	22.3	176.29	620	423.11	21.5	525.88	21.9
AN CH 320-W-2	217.81	766	522.7 4	26.3	653.42	26.7	209.28	736	502.27	25.9	627.83	26.3

- **Water Cooled – Reciprocating Compressor – One Circuit**

Table 28-Technical Data Reciprocating Compressor								
Models		AN CH 15-W-1	AN CH 20-W-1	AN CH 25-W-1	AN CH 30-W-1	AN CH 35-W-1	AN CH 40-W-1	AN CH 50-W-1
Nominal Cooling Capacity	RT	15	20	25	30	35	40	50
Compressor	Type	Reciprocating						
	Quantity	1	1	1	1	1	1	1
Refrigerant		R134a , R407C , R22						
Oil Charge		2.6	2.6	4.5	4.5	4.75	4.75	4.75
Condenser	Type	Shell & Tube						
	Quantity	1	1	1	1	1	1	1
Evaporator	Type	Shell & Tube						
Weight	kg	760	800	860	950	1150	1300	1350

Table 29-Technical Data Reciprocating Compressor									
Models		AN CH 20-W-2	AN CH 30-W-2	AN CH 40-W-2	AN CH 50-W-2	AN CH 60-W-2	AN CH 70-W-2	AN CH 80-W-2	AN CH 100-W-2
Nominal Cooling Capacity	RT	20	30	40	50	60	70	80	100
Compressor	Type	Reciprocating							
	Quantity	2	2	2	2	2	2	2	2
Refrigerant	type	R134a , R407C , R22							
Oil Charge	lit	2.6	2.6	2.6	4.5	4.5	4.75	4.75	4.75
Condenser	Type	Shell & Tube							
	Quantity	2	2	2	2	2	2	2	2
Evaporator	Type	Shell & Tube							
Weight	kg	850	1000	1350	1350	1820	1930	2020	2200

Performance Data

Reciprocating Compressor-R22

Leaving Chilled Water Temperature: 45°F (7.2°C)

COP Range: 4.4 - 4.9

Model	Condenser Entering/Leaving Temperature 30/35°C						Condenser Entering/Leaving Temperature 33/38°C					
	Actual Capacity		Chilled Water		Condenser Water		Actual Capacity		Chilled Water		Condenser Water	
	RT	kW	GPM	P.D Ft Of Water	GPM	P.D Ft Of Water	RT	kW	GPM	P.D Ft Of Water	GPM	P.D Ft Of Water
AN CH 15-W-1	12.2	42.9	29.28	3.4	36.6	8.1	11.77	41.4	28.26	3.1	35.32	7.8
AN CH 20-W-1	14.33	50.4	34.4	4.6	43	8.4	13.82	48.6	33.17	4.2	41.47	8
AN CH 25-W-1	19.03	66.9	45.67	5.4	57.08	14.4	18.37	64.6	44.1	5	55.12	13.7
AN CH 30-W-1	22.01	77.4	52.38	8.3	66.04	8.2	21.27	74.8	51.06	7.6	63.82	7.8
AN CH 35-W-1	28.53	100.3	68.46	7.8	85.58	9.7	27.56	96.9	66.14	6.9	82.68	8.7
AN CH 40-W-1	32.76	115.2	78.63	6.9	98.29	10.1	31.63	111.2	75.9	6.6	94.88	9.9
AN CH 50-W-1	39.36	138.4	94.47	8.4	118.09	12.6	38.03	133.7	91.26	6.1	114.08	10.1
AN CH 20-W-2	17.63	62	42.32	11.3	52.9	7.6	17.01	59.8	40.82	9.9	51.02	7.6
AN CH 30-W-2	24.4	85.8	58.57	10.4	73.21	8.1	23.55	82.2	56.52	9.7	70.65	7.9
AN CH 40-W-2	28.67	100.8	68.81	8.9	86.01	8.4	27.65	97.2	66.35	8.2	82.94	8.1
AN CH 50-W-2	38.05	133.8	91.33	13.9	114.16	14.6	36.75	129.2	88.19	13	110.24	13.8
AN CH 60-W-2	44.03	154.8	105.67	12.8	132.08	8.2	42.55	149.6	102.12	11.9	127.65	7.8
AN CH 70-W-2	57.05	200.6	136.93	12.8	171.16	9.8	55.12	193.8	132.29	11.7	165.36	9.4
AN CH 80-W-2	65.53	230.4	157.27	12.2	196.59	10.1	63.25	222.4	151.81	11.7	189.76	9.9
AN CH 100-W-2	78.73	276.8	188.94	11.9	236.18	9.9	76.05	267.4	182.53	11.5	228.16	10.2

- Water Cooled Chillers Dimensions

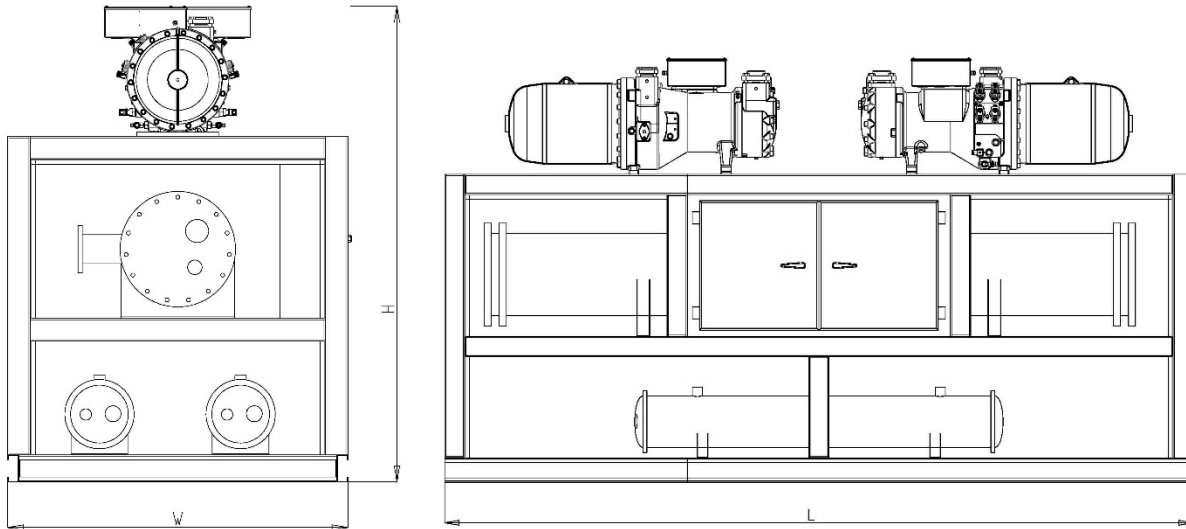

Table 31

Model	H	W	L	Eva. Water side Connections
AN CH 10-W-2	1700	700	2200	1 1/2
AN CH 15-W-2	1800	700	2200	1 1/2
AN CH 20-W-2	2000	800	2200	2 1/2
AN CH 25-W-2	2000	800	2200	2 1/2
AN CH 30-W-2	2000	800	2200	2 1/2
AN CH 40-W-2	2000	800	2800	2 1/2
AN CH 50-W-2	2100	800	2800	3
AN CH 60-W-2	2200	800	2800	3
AN CH 70-W-2	2200	800	2800	3
AN CH 80-W-2	2200	800	2800	4
AN CH 100-W-2	2200	1200	3800	4
AN CH 120-W-2	2300	1200	3800	4
AN CH 140-W-2	2300	1200	3800	4
AN CH 160-W-2	2300	1200	3800	5
AN CH 180-W-2	2400	1500	3800	5
AN CH 200-W-2	2400	1500	3800	5
AN CH 220-W-2	2400	1500	3800	5
AN CH 250-W-2	2400	1500	4800	5
AN CH 280-W-2	2500	1500	4800	6
AN CH 320-W-2	2500	1500	4800	6
AN CH 480-W-2	2500	1500	4800	6
AN CH 560-W-2	2500	1500	4800	8

Note:

Dimensions are in mm

CONTACT US!

- Central Office : 021-48402
- Customer Voice : (ext6)
- Central Office Fax : (ext116)
- Factory Phone : 086-45250025
- Factory Fax : 086-45250022
- Email : info@azarnasim.com
- Address : No,304,The 3th Floor,
Toupaz Complex, Next to Yaran Park, After Abazar Cross
roads, Ayatollah Kashani Blvd,The Second Sq.Of Sadeghieh
Tehran, IRAN.